

# INSTALLATION INSTRUCTIONS

Accessory	Application	Publications No.
HEATED STEERING WHEEL P/N 08U97-TZ5-200A	2015 MDX	BII 51611
		Issue Date MAY 2014

## PARTS LIST

Steering wheel



Body cover A  
(May not be used)

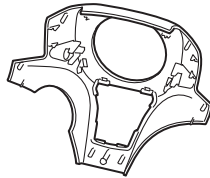

Body cover B (with ACC + LKAS)  
(May not be used)

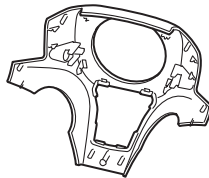

Control unit

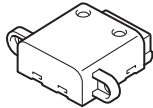

HSW switch

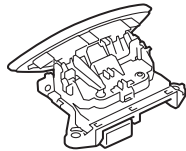

HSW switch cover



Cable reel cord A  
(May not be used)

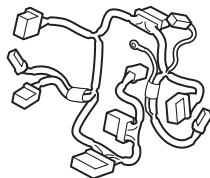

Cable reel cord B (with ACC + LKAS)  
(May not be used)

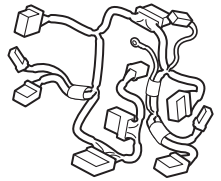

Bracket



Cable reel

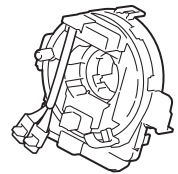

Relay

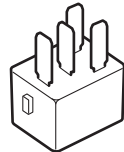

10A Fuse

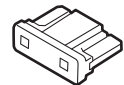

2 Self-tapping screws, 4 x 16 mm



2 Self-tapping screws, 3 x 10 mm



2 Screws



2 TORX bolts



Steering wheel bolt



Information

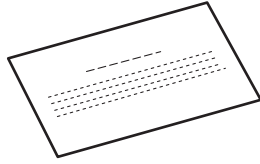

### TOOLS AND SUPPLIES REQUIRED

- Phillips screwdriver
- 10 mm Open end wrench
- 10 mm Hex bit
- Ratchet
- T30 TORX bit
- Torque wrench
- Steering wheel puller
- Shop towel
- Tape
- HDS/MVCI

The following tools are available through the Honda Tool and Equipment Program. On the iN, click on: Service > Service Bay > Tool and Equipment Program, then enter the number under "Search." Or, call 888-424-6857.

- Trim Tool Set (T/N SOJATP2014)
- Plastic Trim Tool (T/N SILTRIMTL10)

### Illustration of the Heated Steering Wheel in the Vehicle

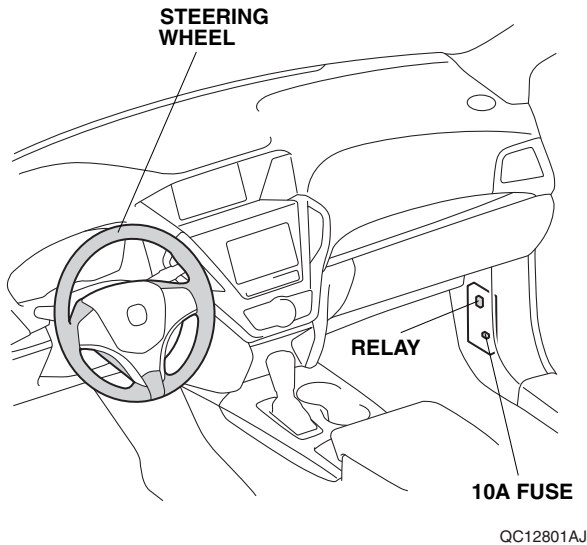

### INSTALLATION

**Client Information:** The information in this installation instruction is intended for use only by skilled technicians who have the proper tools, equipment, and training to correctly and safely add equipment to your vehicle. These procedures should not be attempted by "do-it-yourselfers."

#### NOTE:

- Observe all safety notes and precautions in the Service Manual in addition to those in this Installation Instruction.
- Be careful not to damage the vehicle.
- After installing the steering wheel, you must align the steering wheel spoke angle to the straight ahead position by adjusting the front toe.

1. Turn the steering wheel so the front wheels are in the straight-ahead position.
2. Lower the steering wheel by moving the adjustment switch.

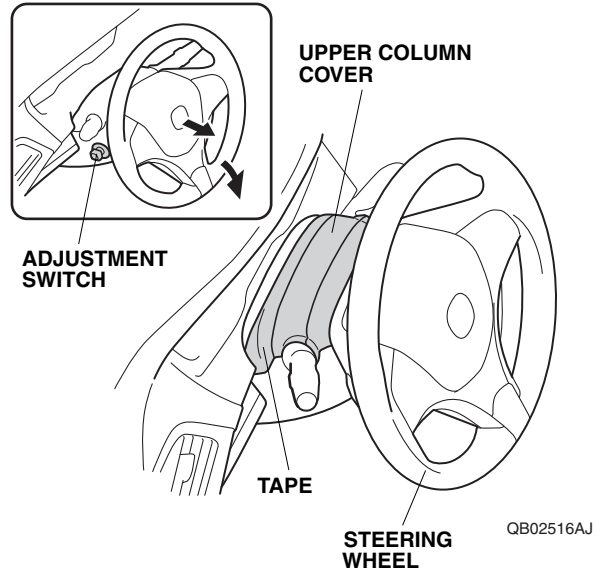

3. Attach the tape to the upper column cover as shown.

4. Disconnect the negative cable:
  - Wrap a shop towel around the hood latch.

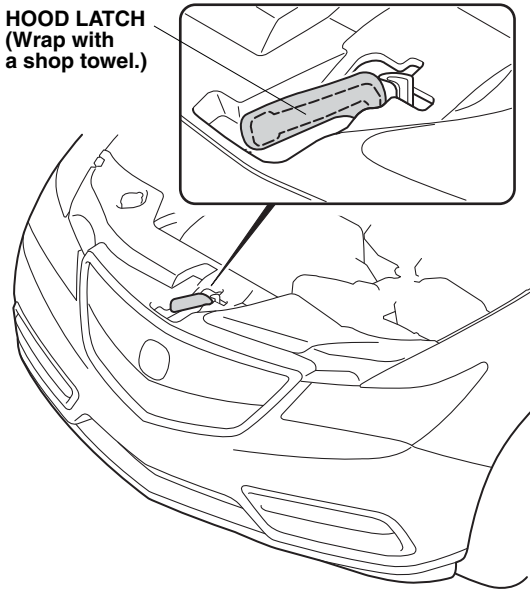

QBN1201BK

- Remove the front bulkhead cover (10 clips).

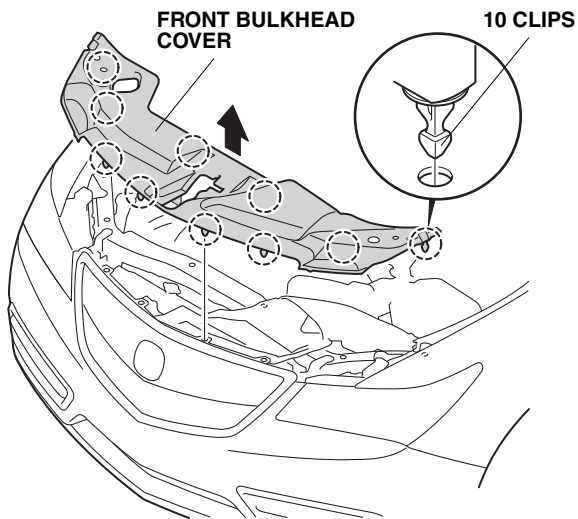

QBN1202BK

- Remove the intake air tube (two clips).
  - Disconnect the negative cable from the battery, and wait at least 3 minutes before you start to install the steering wheel.
- NOTE:** The steering wheel automatically moves fully in and up. Make sure that the steering wheel is not interfering with the vehicle parts.

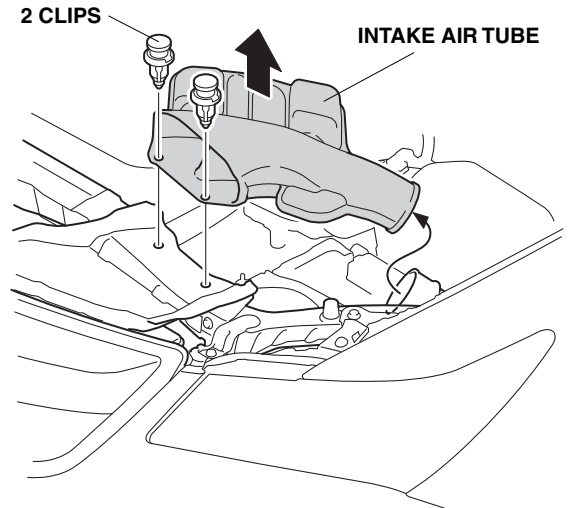

QBN1504E

5. Pull away the door opening seal, and remove the driver's dashboard side lid (four clips).

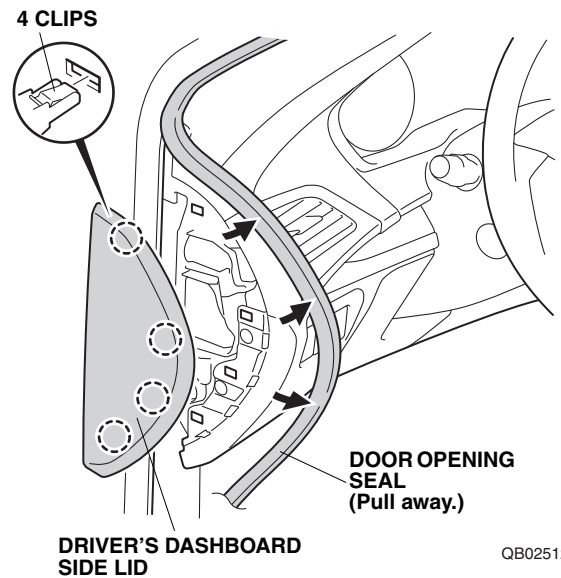

QB02512AJ

- Remove the driver's dashboard lower cover (two self-tapping screws, nine clips, and unplug the vehicle connectors).

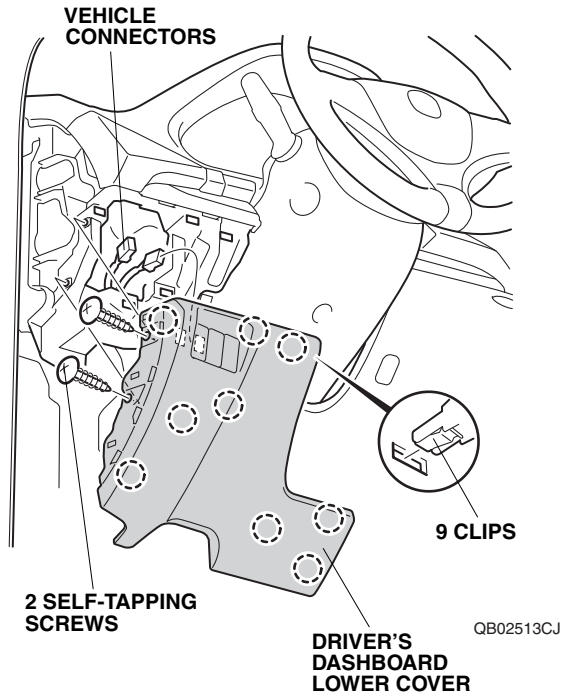

- Remove the two TORX bolts.

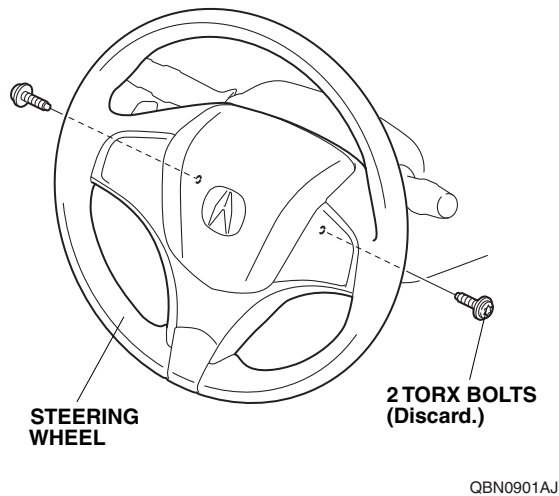

- Unplug the two vehicle 2-pin connectors (pull up on the locking tabs) and the vehicle 1-pin connector. NOTE: Be careful not to damage the connectors.

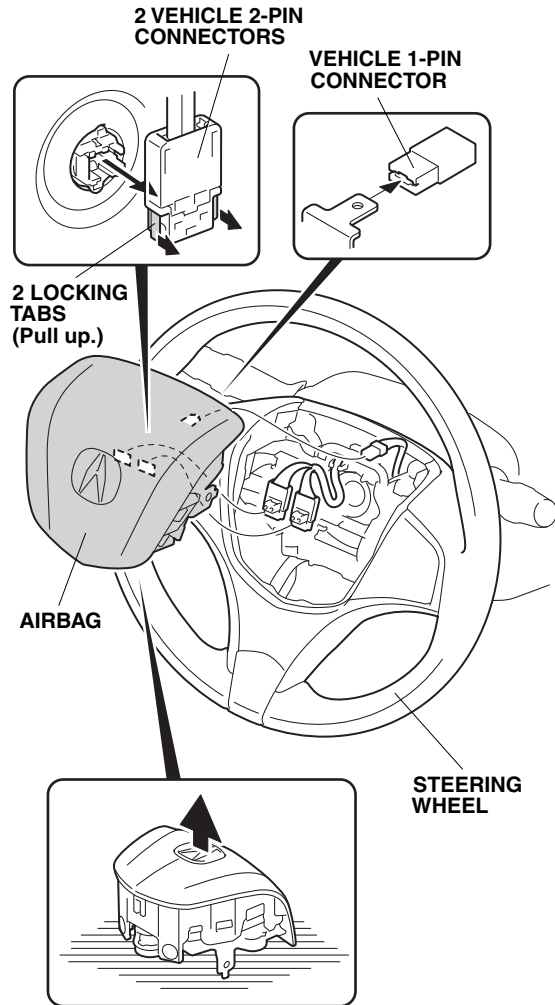

QBN0902BJ

- Remove the airbag. Do not drop the removed airbag or hit it on an object. Place the removed airbag on a safe place with the pad surface (top) facing upward.

10. With the front wheels aligned in the straight forward position, unplug the vehicle 20-pin connector from the cable reel, and loosen the steering wheel bolt.

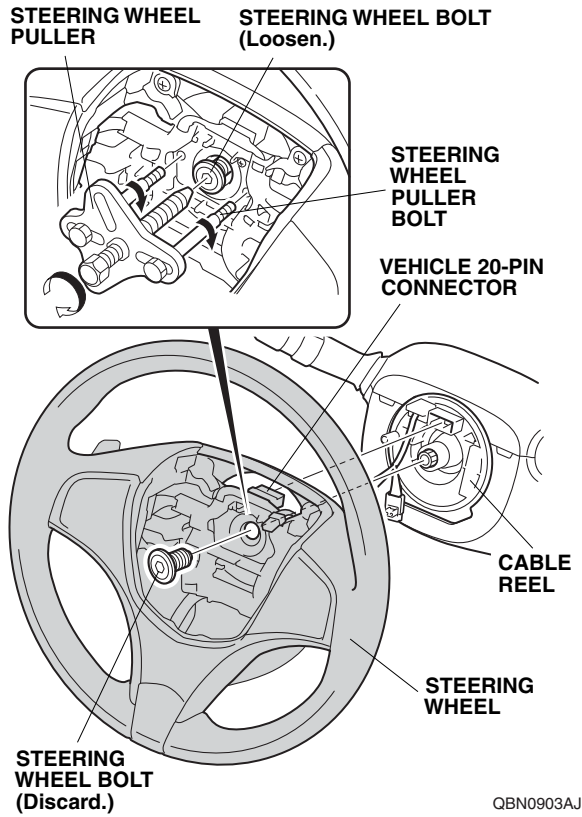

11. Using a steering wheel puller, release the steering wheel. Do not thread the steering wheel puller bolts in more than 5 mm (0.2 in.). When removing the vehicle steering wheel, take care not to move the front wheels.
12. Remove the steering wheel bolt, then remove the steering wheel.

13. Using a plastic trim tool, release the two retaining tabs.

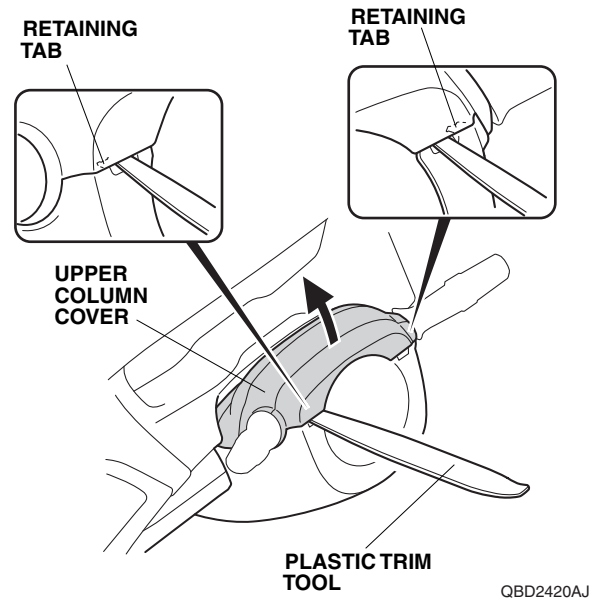

14. Release the upper column cover (two retaining tabs and four hooks), and secure the upper column cover to the dashboard with the tape.

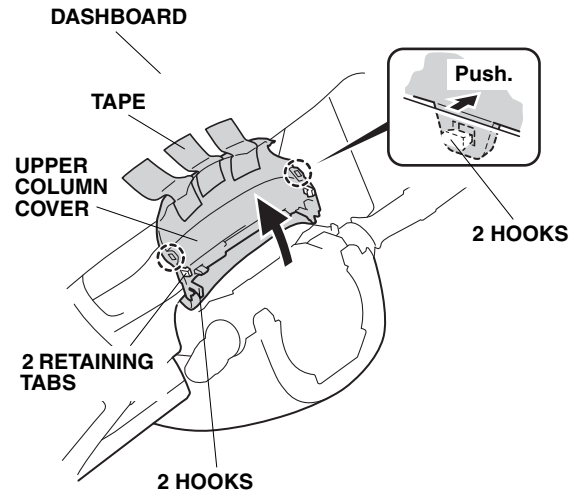

- Remove two self-tapping screws from the lower column cover.

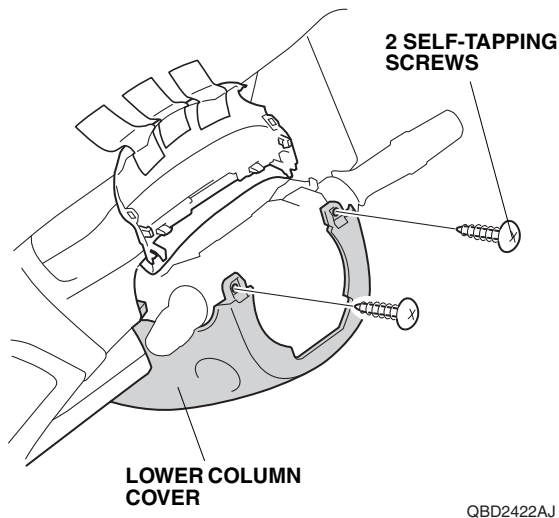

- Remove the bolt from the driver's dashboard center lower cover.

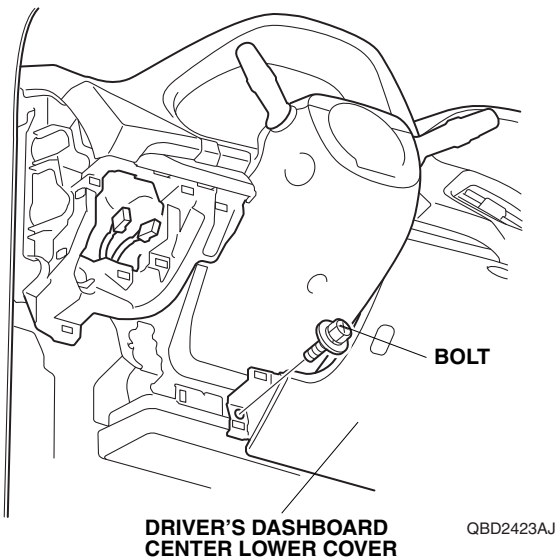

- Remove the driver's dashboard center lower cover (six clips, and unplug the vehicle connector and temperature sensor).

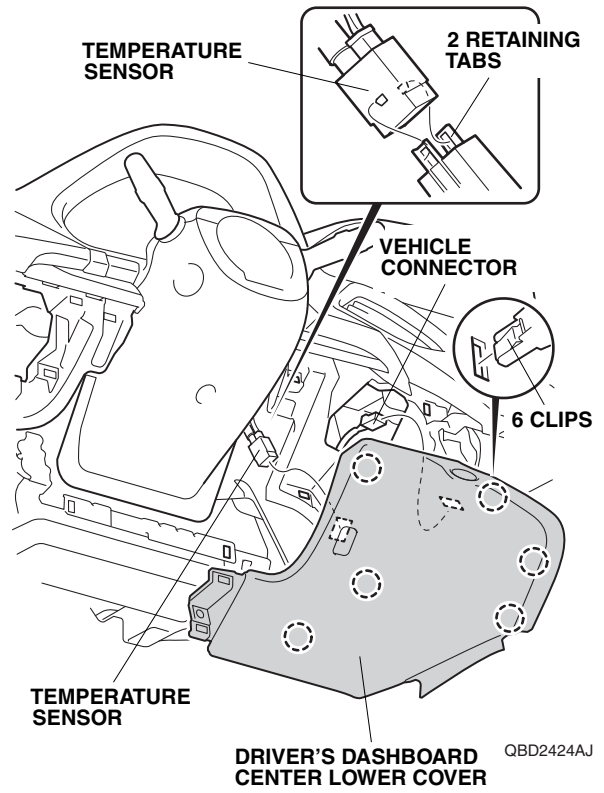

- Remove the lower column cover (one self-tapping screw, and unplug the vehicle connector).

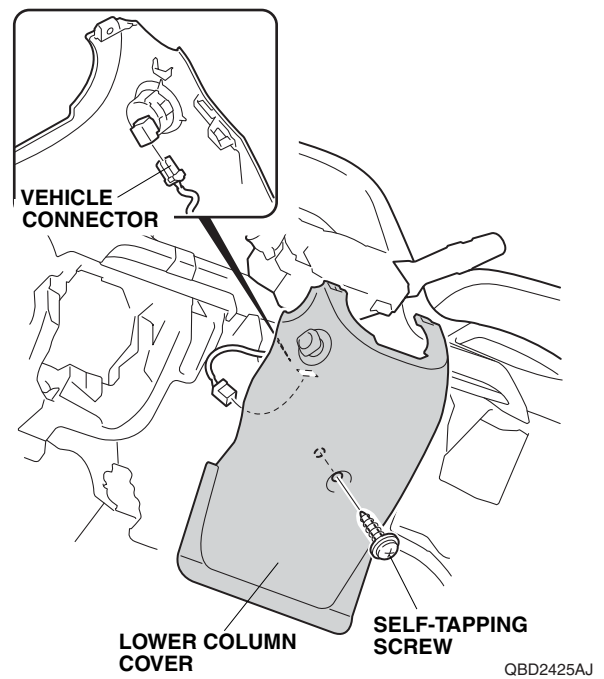

19. Unplug the vehicle connectors from the cable reel.

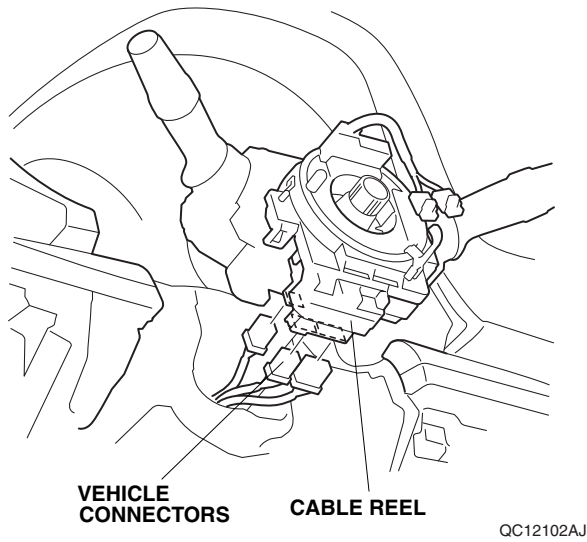

20. Remove the cable reel (three retaining tabs).

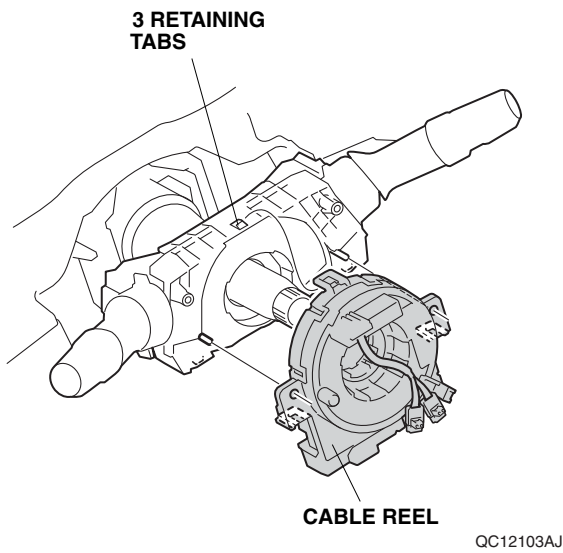

21. Remove the steering angle sensor.

NOTE: Do not let the inner tabs turn on the steering angle sensor.

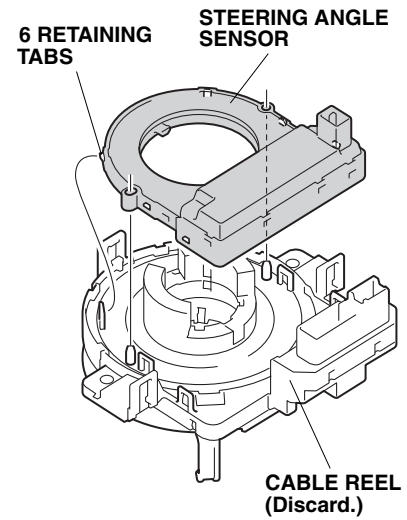

22. Install the steering angle sensor to the new cable reel.

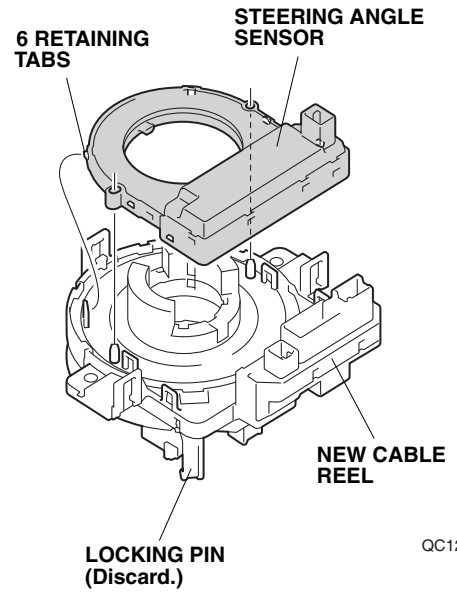

23. Remove the tape from the vehicle 2-pin connector.

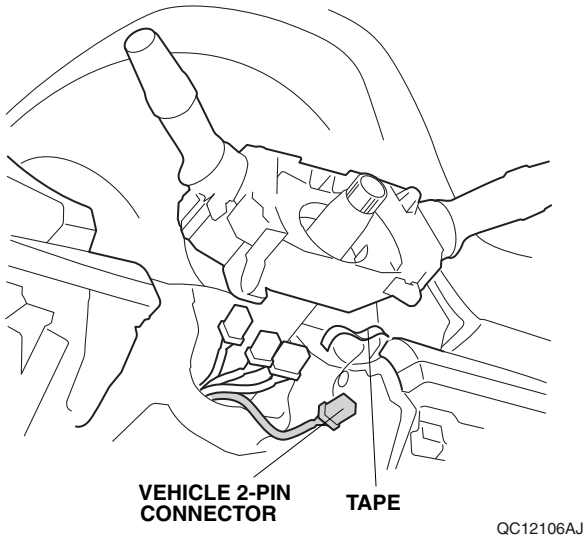

24. Install the new cable reel.

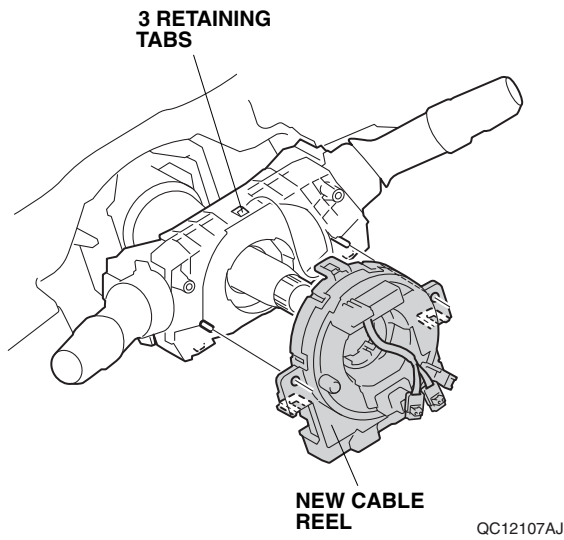

25. Plug the vehicle 2-pin connector to the new cable reel 2-pin connector.

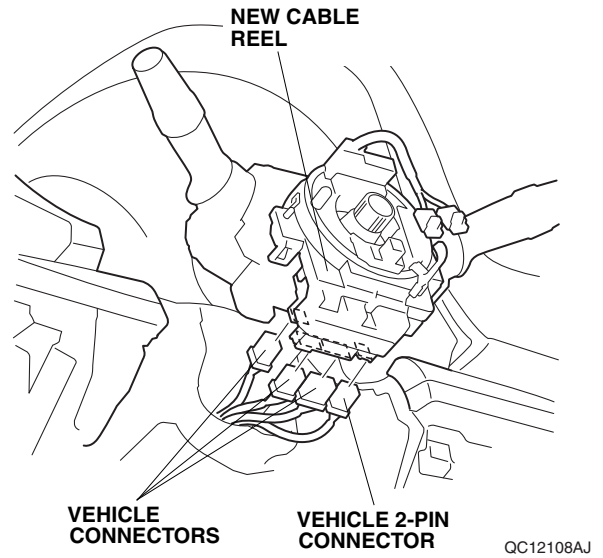

26. Plug the vehicle connectors to the new cable reel.

27. Using a plastic trim tool, remove the cap from the body cover (four retaining tabs).

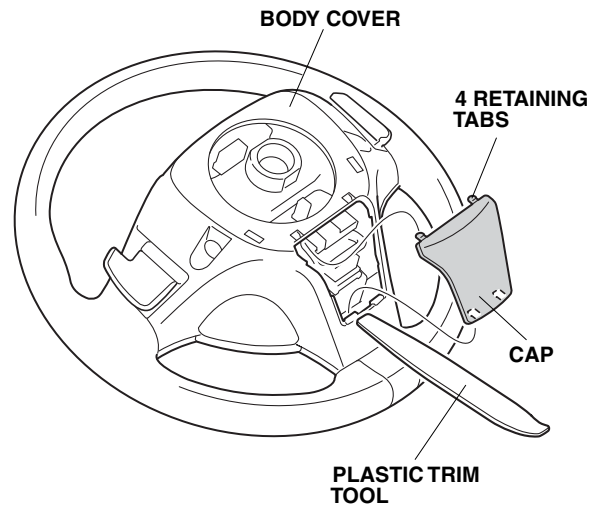



28. Remove the body cover (two self-tapping screws, two retaining tabs, and one clip).

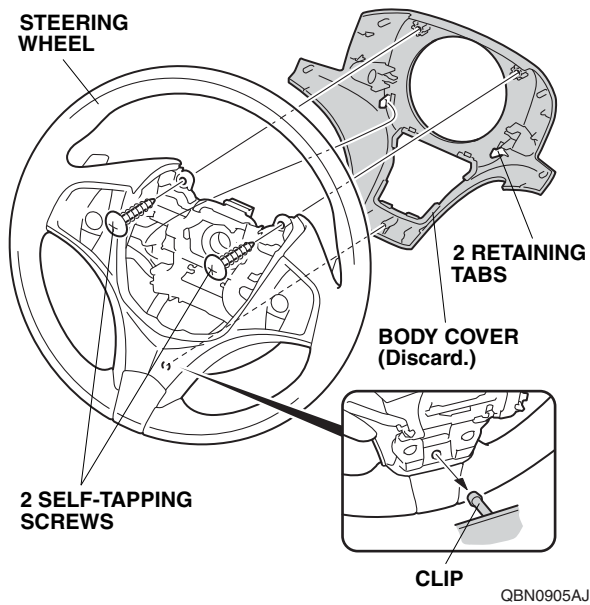

29. Remove the left and right paddle shifters from the steering wheel (unplug two connectors and four screws).

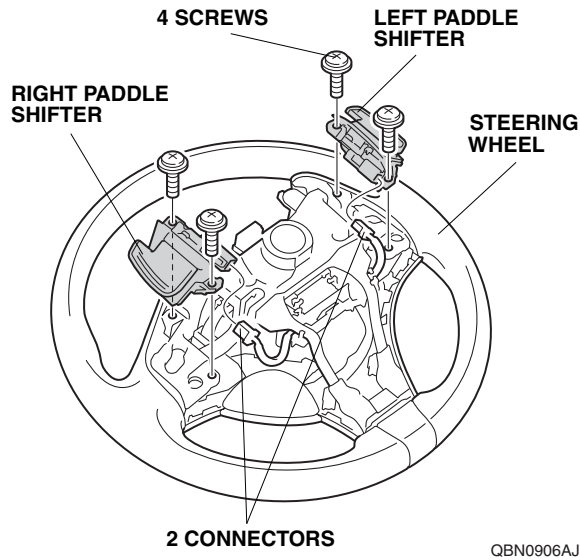

30. Remove the screw(s).

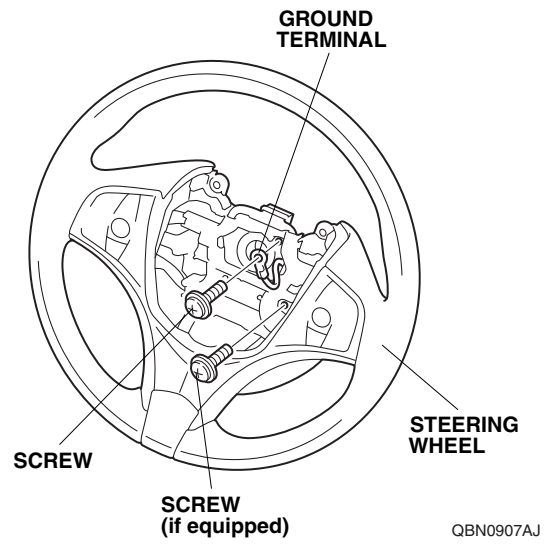

31. Remove the six self-tapping screws.

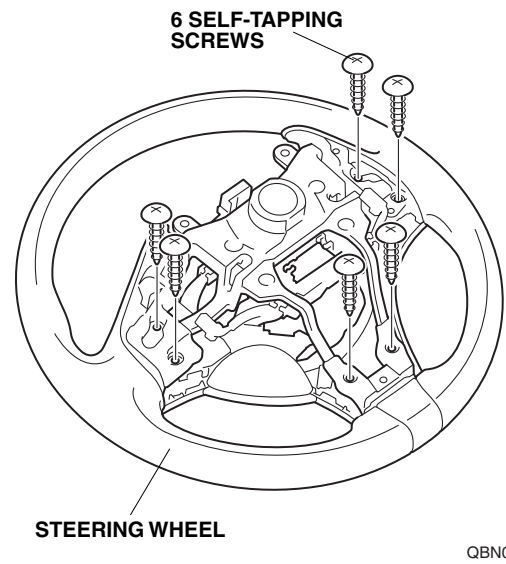

32. Remove the switch assembly and cable guide (four retaining tabs).

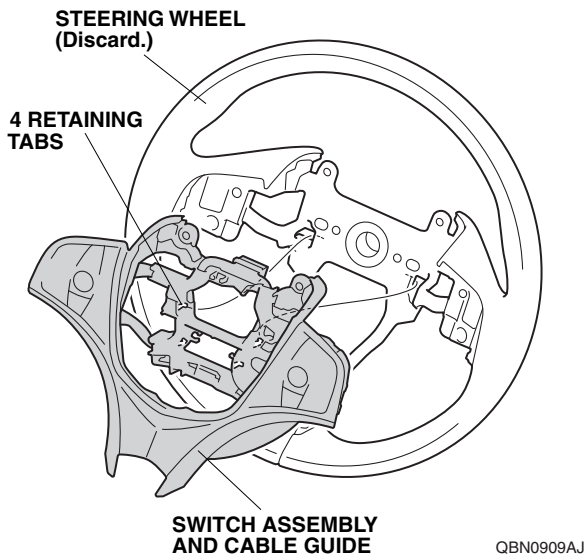

33. Remove the cable guide from the switch assembly (two retaining tabs, and unplug the cable reel cord 16-pin connectors and cable reel cord 5-pin connector if equipped).

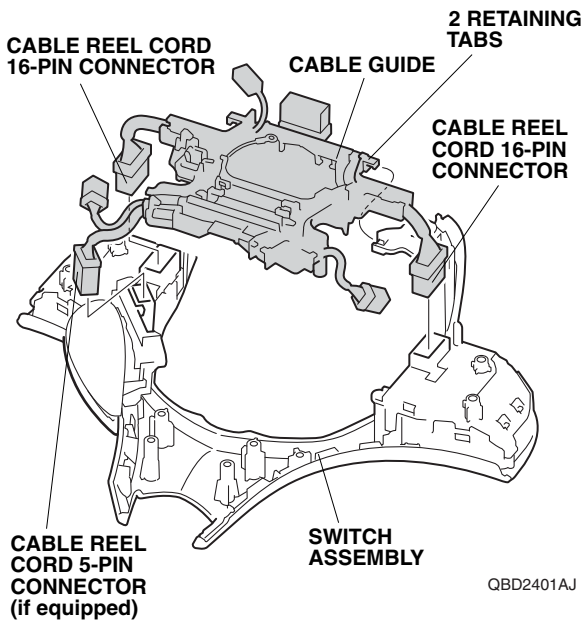

34. Remove the cable reel cord from the cable guide.

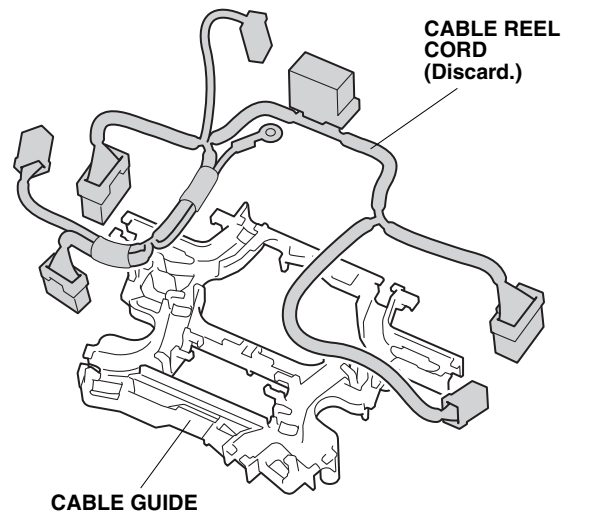

35. Install the new cable reel cord to the cable guide.

With ACC + LKAS

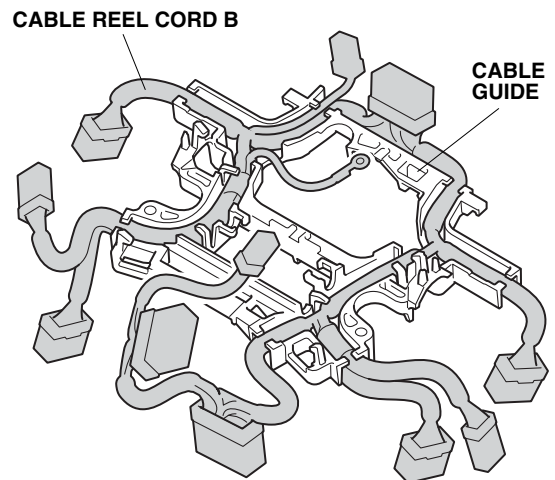

Without ACC + LKAS

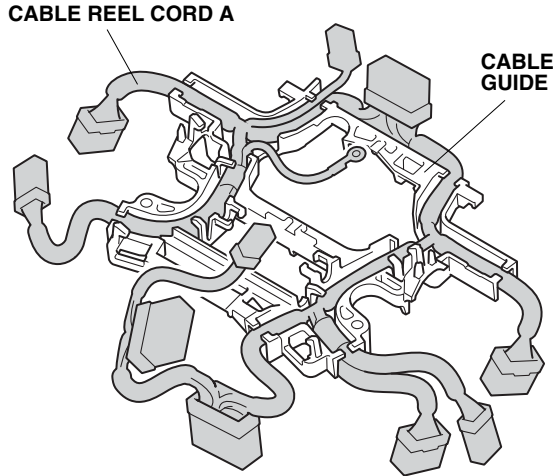

QBD2404AJ

36. Install the control unit to the switch assembly with two 4 x 16 mm self-tapping screws.

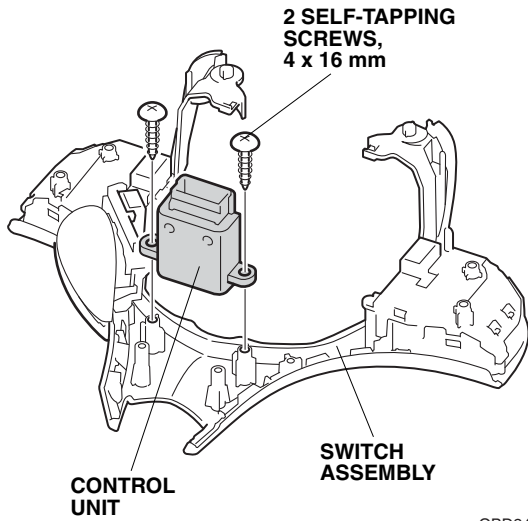

QBD2405AJ

37. Install the HSW switch to the switch assembly with two 3 x 10 mm self-tapping screws.

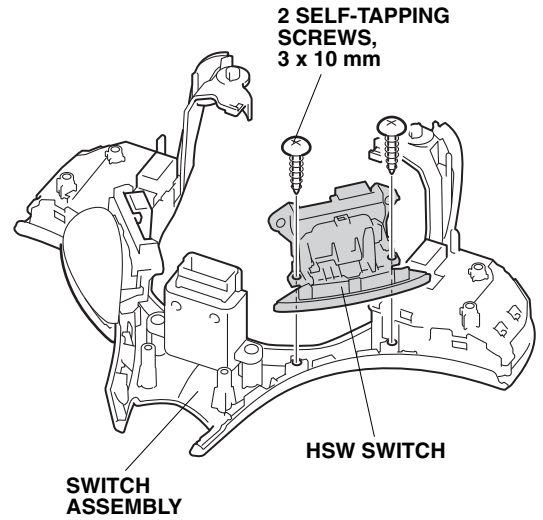

QBD2406AJ

38. Install the HSW switch cover to the HSW switch.

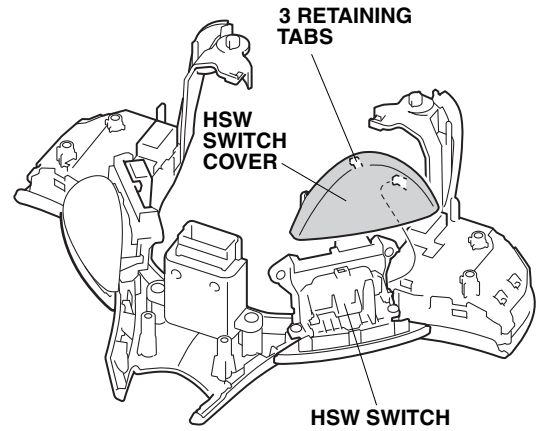

QBD2407AJ

39. Install the cable guide to the switch assembly.

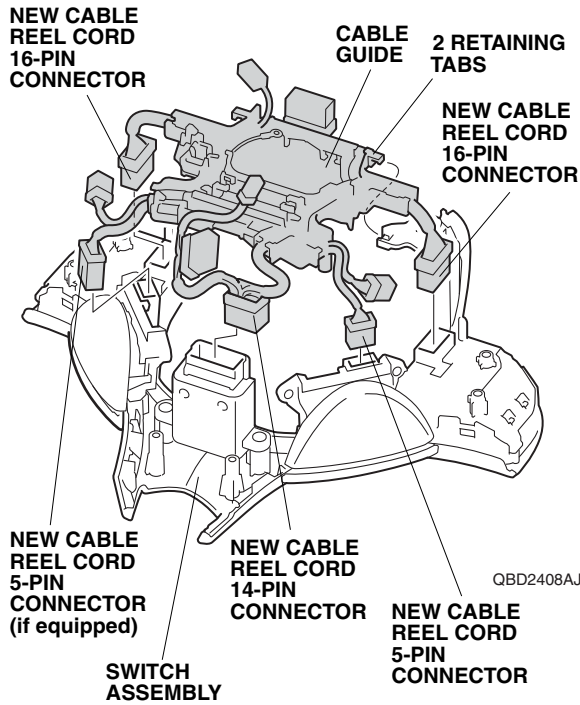

40. Plug the new cable reel cord connectors.

41. Install the switch assembly and cable guide to the new steering wheel.

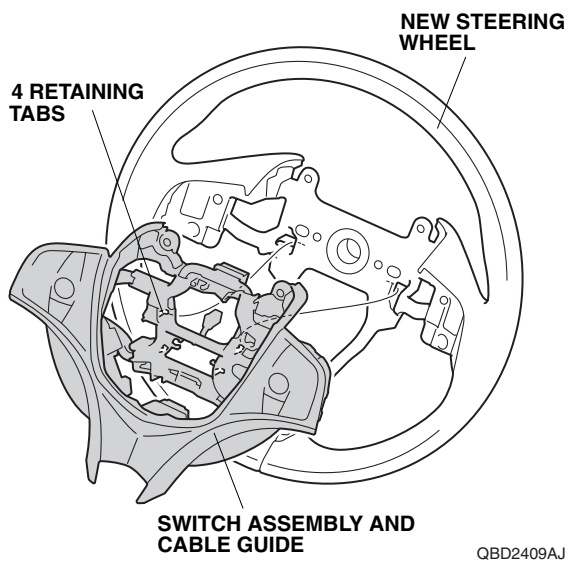

42. Plug the new cable reel cord 4-pin connector to the new steering wheel 4-pin connector, and attach the 4-pin connectors to the cable guide.

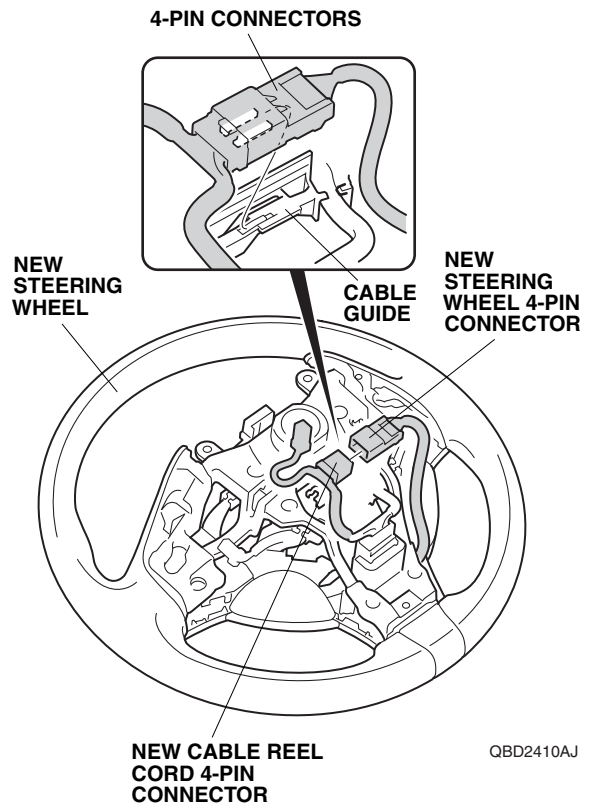

43. Install the bracket to the switch assembly and cable guide with two screws.

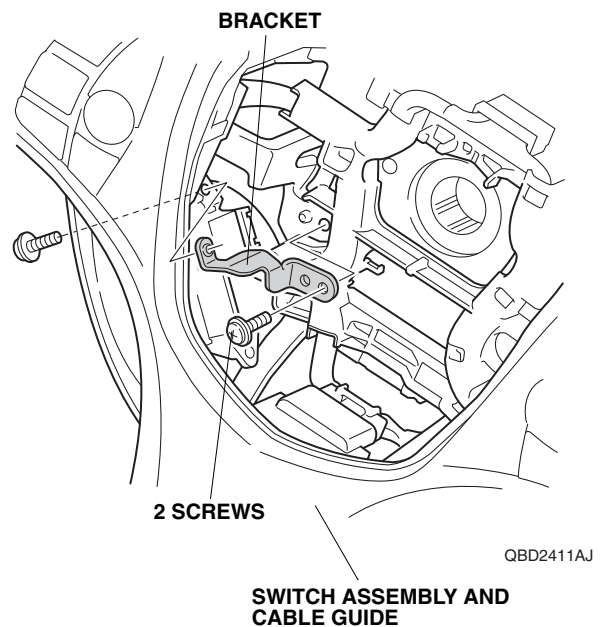

44. Secure the switch assembly and cable guide to the new steering wheel with the six self-tapping screws.

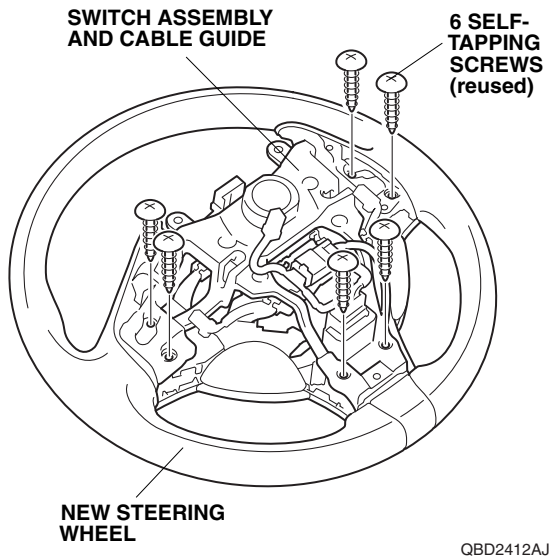

45. Install the screw(s) and ground terminal.

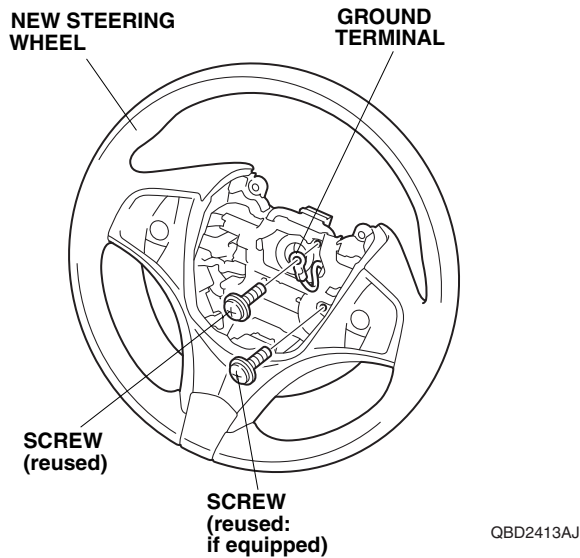

46. Install the left and right paddle shifters to the new steering wheel with four screws.

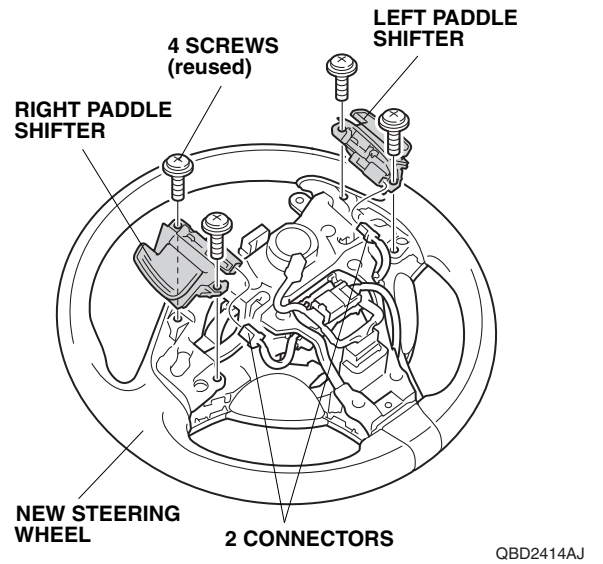

47. Plug two connectors into the left and right paddle shifters.

48. Install the new body cover A or B (with ACC + LKAS) to the new steering wheel with two self-tapping screws.

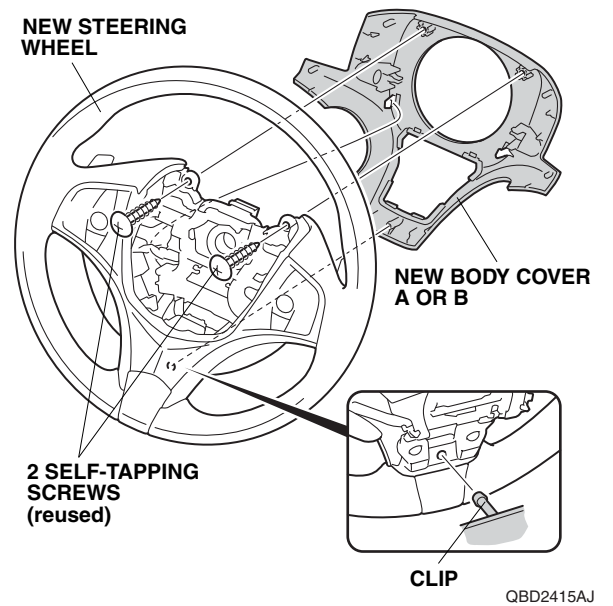

49. Reinstall the cap to the body cover.

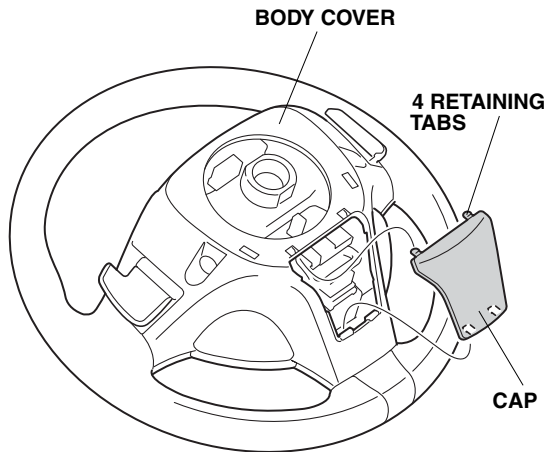

QBD2416AJ

50. Reinstall the lower column cover and upper column cover.

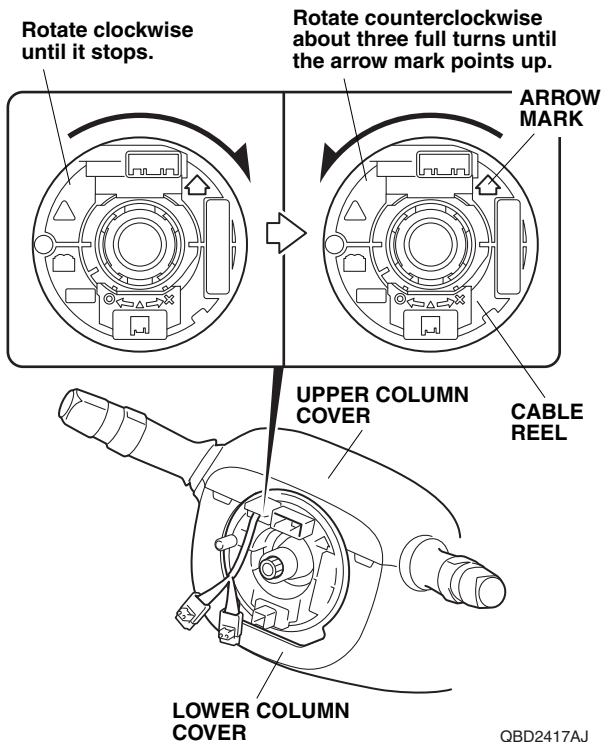

QBD2417AJ

51. Before installing the steering wheel, make sure the front wheels are pointing straight ahead, then center the cable reel. Do this by first rotating the cable reel clockwise until it stops, then rotate it counterclockwise about three full turns. The arrow mark on the cable reel label should point straight up.

52. Install the new steering wheel to the steering column shaft in the straight-ahead position:

- Route the two new cable reel 2-pin connectors through the opening in the new steering wheel.
- Plug the new cable reel cord 20-pin and 2-pin connectors to the new cable reel.
- Check that the wire harnesses are not pinched.

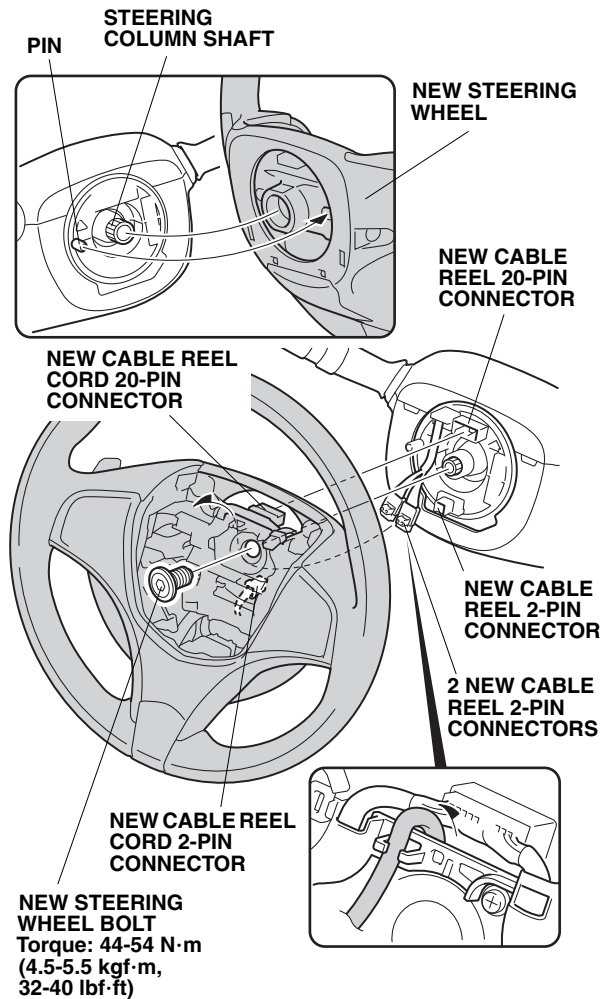

QBD2418AJ

53. Install the new steering wheel bolt. Torque the steering wheel bolt to 44-54 N·m (4.5-5.5 kgf·m, 32-40 lbf·ft).

54. Install the airbag on the new steering wheel with two new TORX bolts (plug two new cable reel 2-pin connectors and one new cable reel cord 1-pin connector).

- Alternately tighten the right and left TORX bolts so that the gaps on the right and left sides between the horn pad and the steering wheel are even. Torque the TORX bolts to 6.9-11.8 N·m (0.7-1.2 kgf·m, 5.1-8.7 lbf·ft).
- TORX bolts are coated with non-hardening thread lock sealant, so they cannot be reused. When installing the steering wheel, be sure to replace the TORX bolts with the ones included in this kit.

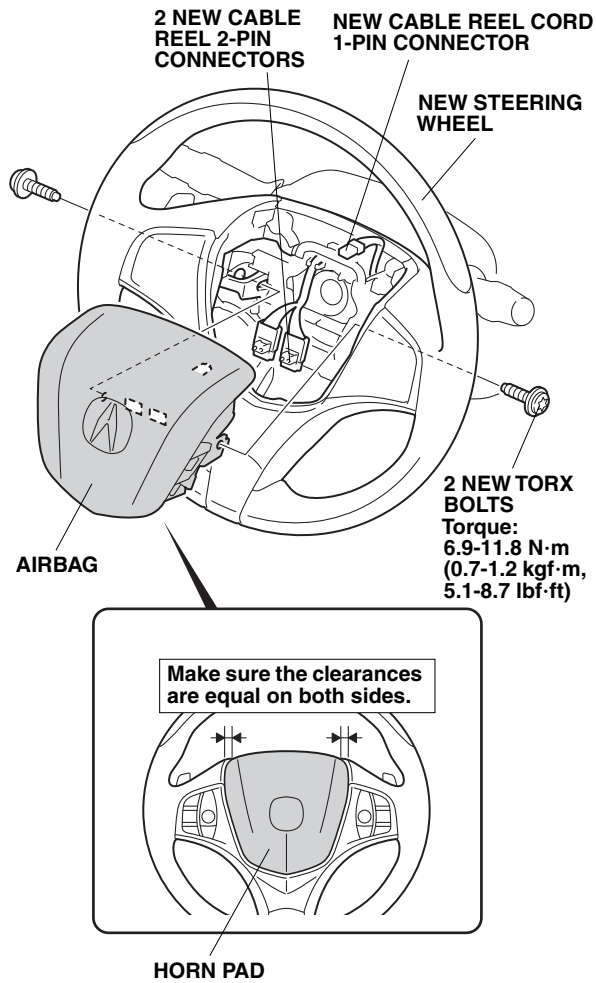

55. Pull away the door opening seal, and remove the passenger's kick panel (two clips).

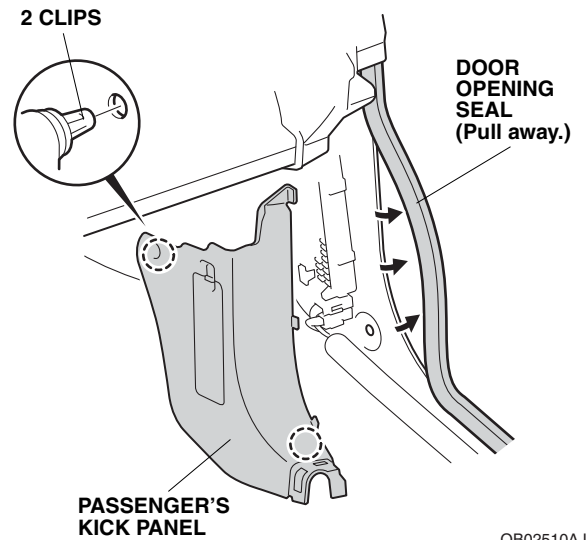

56. Plug the relay and 10A fuse into the passenger's fuse box.

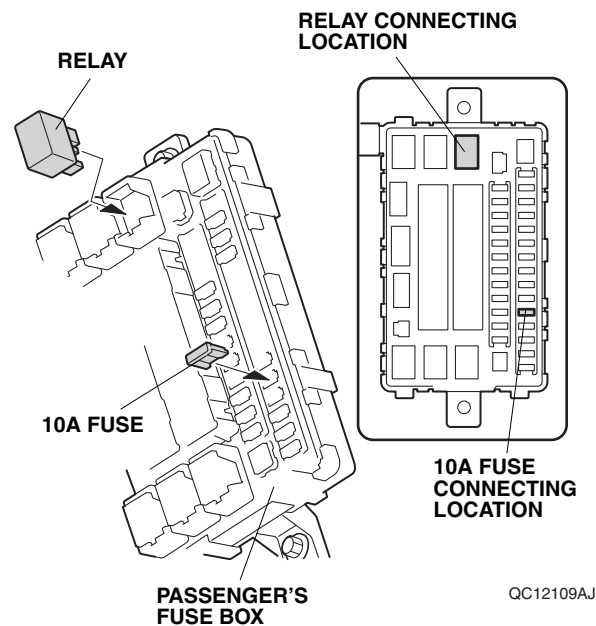

57. Check that all wire harnesses are routed properly and all connectors are plugged in.
58. Reconnect the negative cable to the battery.
59. Reinstall all removed parts.
60. Connect the HDS/MVCI, and clear the DTCs.
61. Inspect the following items. If any abnormality is found, perform troubleshooting as described in the service manual of the vehicle.
  - Press the engine start/stop button to the ON mode: the SRS indicator should come on for about 6 seconds and then go off.
  - Make sure the horn and steering wheel switches work properly.
62. Press and hold the radio power button for two seconds to restore the radio and navi (if equipped) system functions.
63. Reset the clock on vehicles without navigation.
64. Restore the systems back to normal operation as described in the service manual if necessary.
65. Make sure the steering wheel is in the straight-ahead position with the front wheels. If the spoke angle of the steering wheel is not in the straight-ahead position with the front wheels, adjust the front toe as described in the service manual.
66. Do the VSA sensor neutral position memorization as described in the service manual.